

Smart Green-Mode PWM Controller with Multiple Protections

REV: 01

General Description

The LD7523A is a low startup current, current mode PWM controller with green-mode power-saving operation. The SOP-8/DIP-8 package integrates functions such as the leading-edge blanking of the current sensing, internal slope compensation, line compensation, and several protection features including cycle-by-cycle current limit, OVP, OTP, OLP, and brownout protection. It provides the users a high efficiency, low external component counts solution for AC/DC power applications.

Furthermore, to satisfy various protection requirements, both latch-mode protection and auto-recoverable protection can be easily achieved by configuring LD7523A on different operation modes.

The special green-mode control is not only to achieve the low power consumption but also to offer a non-audible-noise operation when the LD7523A is operating under light load or no load condition.

Features

- High-Voltage CMOS Process with Excellent ESD protection
- Very Low Startup Current (< 35 μ A)
- Current Mode Control
- Non-audible-noise Green Mode Control
- UVLO (Under Voltage Lockout)
- LEB (Leading-Edge Blanking) on CS Pin
- Internal Slope Compensation
- Programmable Line Compensation
- OVP (Over Voltage Protection)
- OLP (Over Load Protection)
- OTP (Over Temperature Protection) through a NTC
- Brownout Protection
- Flexibility on Latch/Auto-Recoverable Protection Mode
- 500mA Driving Capability

Applications

- Switching AC/DC Adaptor and Battery Charger
- Open Frame Switching Power Supply
- LCD Monitor/TV Power

Typical Application

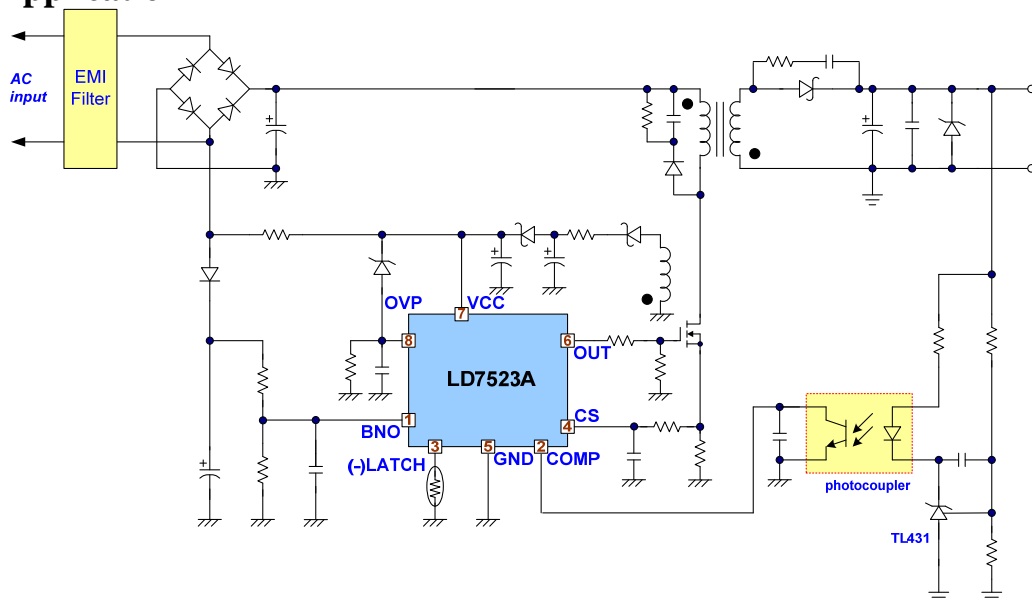

Pin Configuration

SOP-8 & DIP-8(TOP VIEW)



YY : Year code (D: 2004, E: 2005.....)
 WW : Week code
 ## : Production code

Ordering Information

Part number	Package		TOP MARK	Shipping
LD7523A GS	SOP-8	Green Package	LD7523AGS	2500 /tape & reel
LD7523A GN	DIP-8	Green Package	LD7523AGN	3600/tube /carton

The LD7523A is ROHS Complaint/ Green Packaged.

Pin Descriptions

PIN	NAME	FUNCTION
1	BNO	Brownout Protection Pin. Connect a resistor divider from this pin to bulk capacitor voltage to set the brownout level and line compensation. When the voltage of this pin is lower than a threshold voltage, the PWM output will be off.
2	COMP	Voltage feedback pin (same as the COMP pin in UC384X). Connecting a photo-coupler to close the control loop and achieve the regulation.
3	(-) LATCH	Pulling this pin to lower than 2.5V will shutdown the controller to the latch mode until the AC power-on recycling. Connecting a NTC from this pin to ground will achieve the OTP protection function. Keep this pin floating to disable the latch protection.
4	CS	Current sense pin, for sensing the MOSFET current
5	GND	Ground
6	OUT	Gate drive output to drive the external MOSFET
7	VCC	Supply voltage pin
8	OVP	This pin is high-active to provide the OVP function. Connecting a zener or a resistor voltage divider to Vcc will set the OVP level. Whenever the voltage is above 2.5V, the OVP is triggered and the gate drive will be off. Grounding this pin disables the OVP function.

Block Diagram

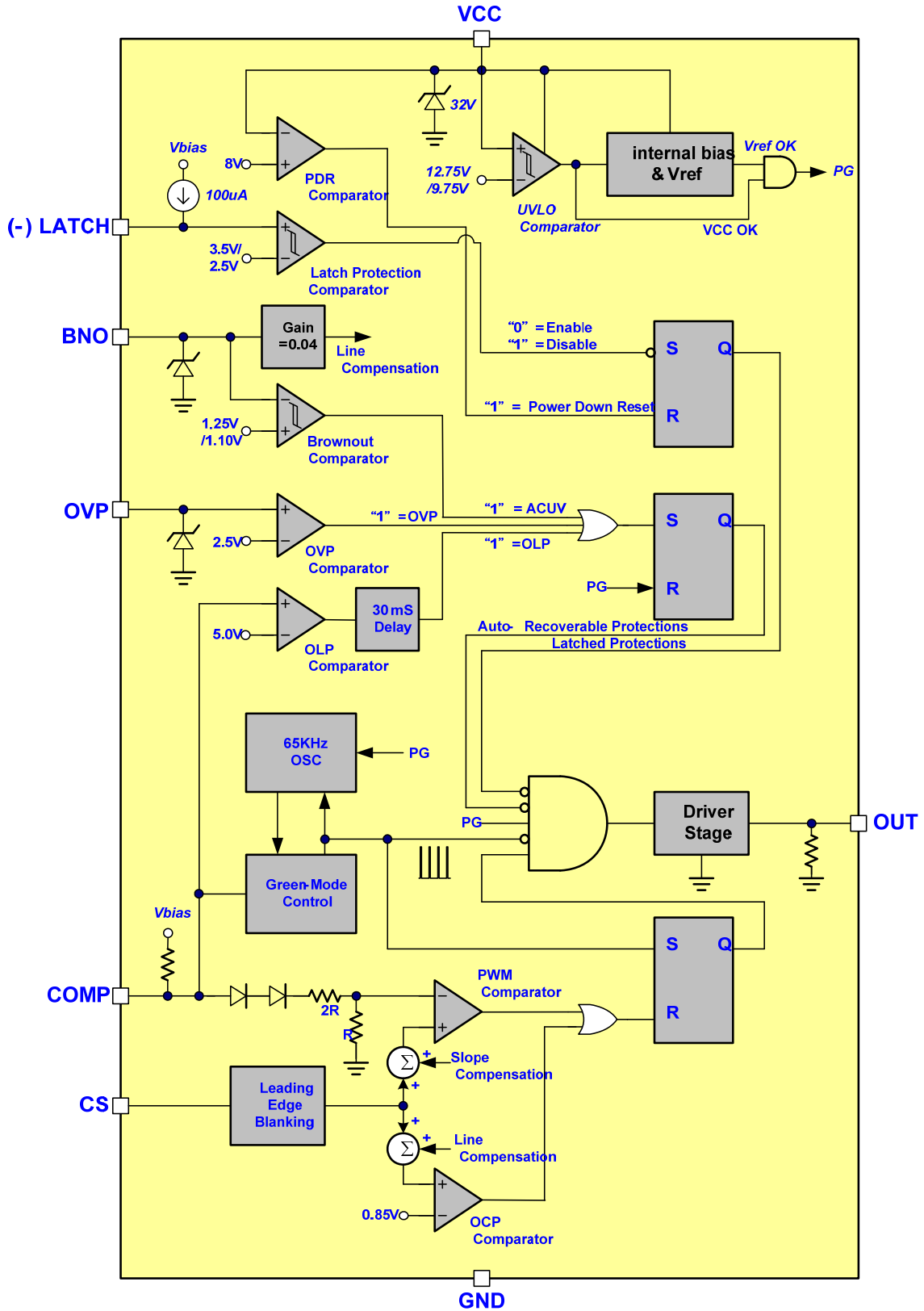

Absolute Maximum Ratings

Supply Voltage VCC.....	30V
COMP, CS, (-) LATCH.....	-0.3 ~7V
OVP, BNO.....	-0.3 ~7V
Junction Temperature.....	150°C
Operating Ambient Temperature.....	-40°C to 85°C
Storage Temperature Range.....	-65°C to 150°C
Package Thermal Resistance (SOP-8).....	160°C/W
Package Thermal Resistance (DIP-8).....	100°C/W
Power Dissipation (SOP-8, at Ambient Temperature = 85°C).....	400mW
Power Dissipation (DIP-8, at Ambient Temperature = 85°C).....	650mW
Lead temperature (Soldering, 10sec).....	260°C
ESD Voltage Protection, Human Body Model	2.5KV
ESD Voltage Protection, Machine Model.....	250V
Gate Output Current.....	500mA

Caution:

Stresses beyond the ratings specified in "Absolute Maximum Ratings" may cause permanent damage to the device. This is a stress only rating and operation of the device at these or any other conditions above those indicated in the operational sections of this specification is not implied.

Electrical Characteristics

($T_A = +25^\circ\text{C}$ unless otherwise stated, $V_{CC}=12.0\text{V}$)

PARAMETER	CONDITIONS	MIN	TYP	MAX	UNITS
Supply Voltage (VCC Pin)					
Startup Current			20	35	μA
Operating Current (with 1nF load on OUT pin)	$V_{\text{COMP}}=0\text{V}$		3.5	5.0	mA
	$V_{\text{COMP}}=3\text{V}$		2.7		mA
	Protection Mode (note 1)		0.7		mA
UVLO (off)		9.0	9.75	10.7	V
UVLO (on)		12.0	12.75	13.5	V
Voltage Feedback (Comp Pin)					
Short Circuit Current	$V_{\text{COMP}}=0\text{V}$		2.5	4.0	mA
Green Mode Threshold VCOMP			2.35		V
Current Sensing (CS Pin)					
Maximum Input Voltage, $V_{\text{CS(OFF)}}$	$V_{\text{BNO}}=0\text{V}$ (note 2)	0.800	0.850	0.900	V
	$V_{\text{BNO}}=1.30\text{V}$	0.748	0.798	0.848	V
	$V_{\text{BNO}}=3.75\text{V}$	0.650	0.700	0.750	V
Leading Edge Blanking Time			350		nS
Input impedance		1			$\text{M}\Omega$
Delay to Output			150		nS
Gate Drive Output (OUT Pin)					
Output Low Level	$V_{\text{CC}}=15\text{V}$, $I_o=20\text{mA}$			1.0	V
Output High Level	$V_{\text{CC}}=15\text{V}$, $I_o=20\text{mA}$	9.0			V
Rising Time	Load Capacitance=1000pF		50	160	nS
Falling Time	Load Capacitance=1000pF		30	60	nS
Oscillator					
Frequency		60	65	70	KHz
Green Mode Frequency			20		KHz
Frequency Temp. Stability	$(-40^\circ\text{C} - 85^\circ\text{C})$			3	$\%$
Frequency Voltage Stability	$(V_{\text{CC}}=12\text{V}-30\text{V})$			1	$\%$
Latch Protection ((-)LATCH Pin)					
(-)LATCH Pin Source Current		92	100	108	μA
Turn-On Trip Level		3.3	3.50	3.7	V
Turn-Off Trip Level		2.40	2.50	2.60	V
(-)LATCH pin de-bounce time		100			μS
De-latch Vcc Level	(PDR, Power Down Reset)	6.8	8.0	8.7	V

Note 1: When OVP, OLP, or Latch Protection is tripped.

Note 2: Guaranteed by design because $V_{\text{CS(off)}}$ can't be measured when $V_{\text{BNO}}=0\text{V}$.

Electrical Characteristics (Continued)

($T_A = +25^{\circ}\text{C}$ unless otherwise stated, $V_{CC}=12.0\text{V}$)

PARAMETER	CONDITIONS	MIN	TYP	MAX	UNITS
Brownout Protection & Line Compensation (BNO Pin)					
Brownout Turn-On Trip Level		1.20	1.25	1.30	V
Brownout Turn-Off Trip Level		1.05	1.10	1.15	V
Saturation Voltage	$I_{BNO}=1.5\mu\text{A}$		5.0		V
Line Compensation Ratio			0.04		V/V
Over Voltage Protection (OVP Pin)					
OVP Trip Level		2.35	2.50	2.65	V
Saturation Voltage	$I_{BNO}=1.5\mu\text{A}$		5.0		V
OVP de-bounce time		100			μS
OLP (Over Load Protection)					
OLP Trip Level	$V_{COMP(OLP)}$		5.0		V
OLP Delay Time	$V_{COMP}>5.2\text{V}$		30		mS

Typical Performance Characteristics

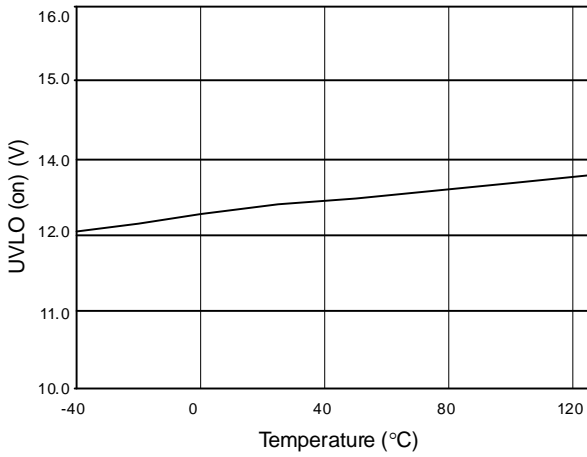

Fig. 1 UVLO (on) vs. Temperature

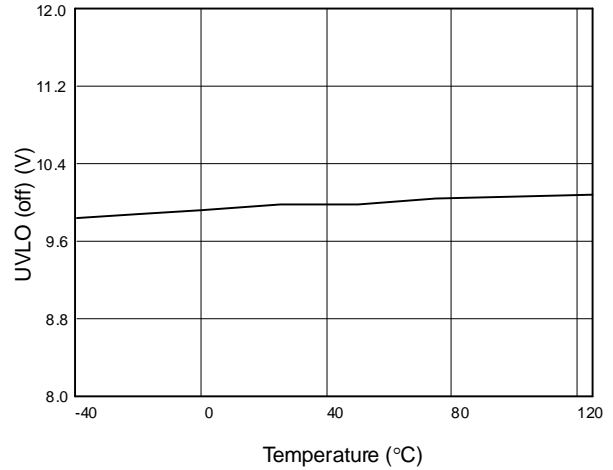

Fig. 2 UVLO (off) vs. Temperature

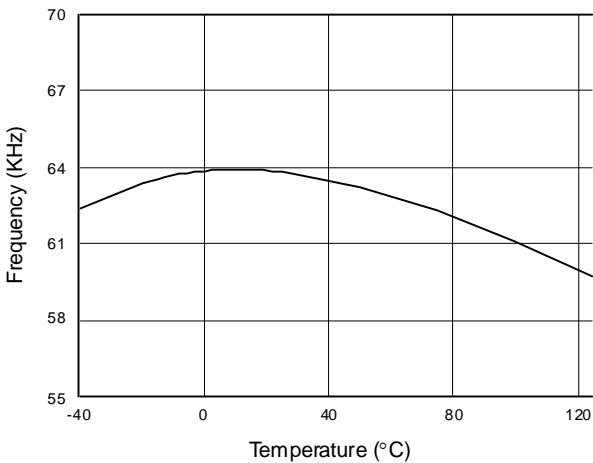

Fig. 3 Frequency vs. Temperature

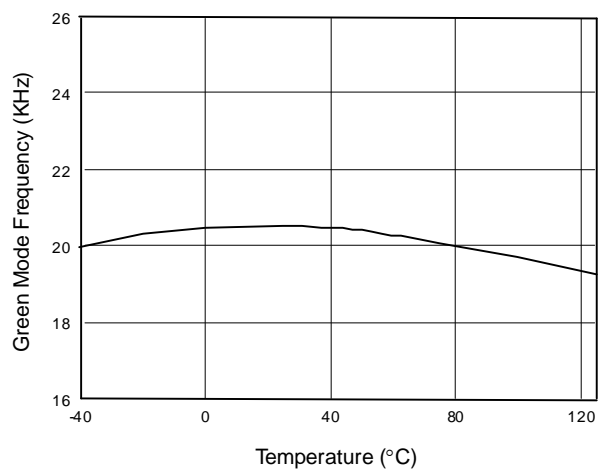

Fig. 4 Green Mode Frequency vs. Temperature

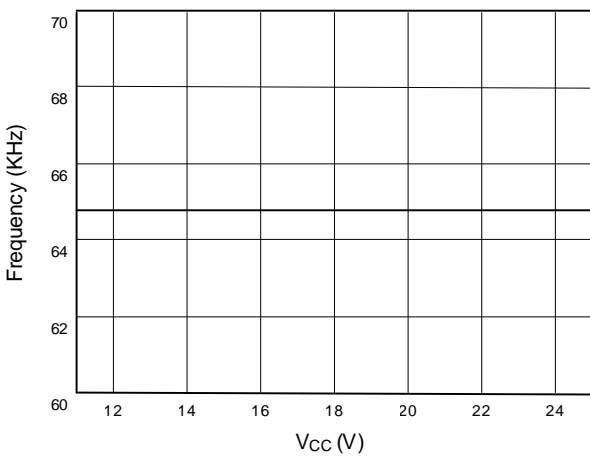

Fig. 5 Frequency vs. Vcc

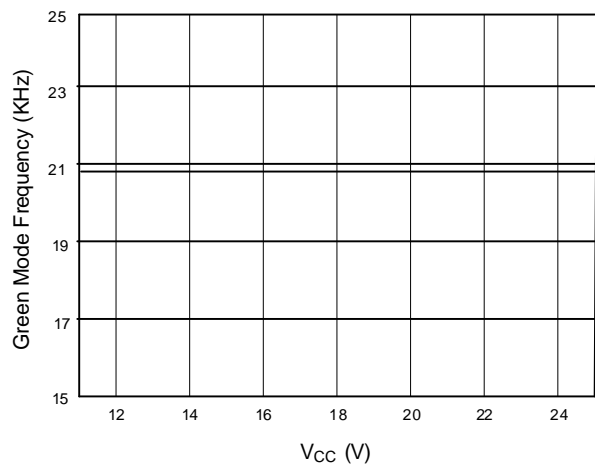

Fig. 6 Green Mode Frequency vs. Vcc

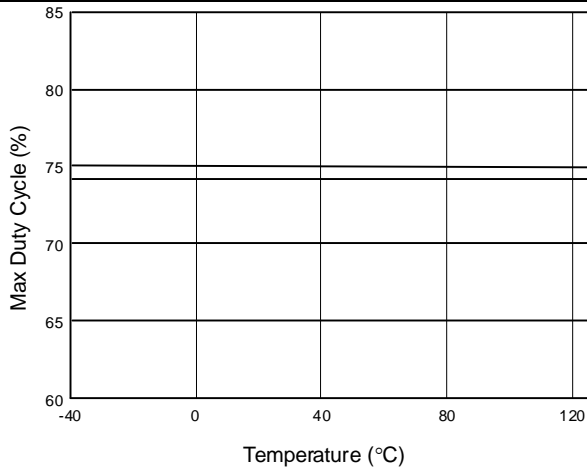

Fig. 7 Max Duty Cycle vs. Temperature

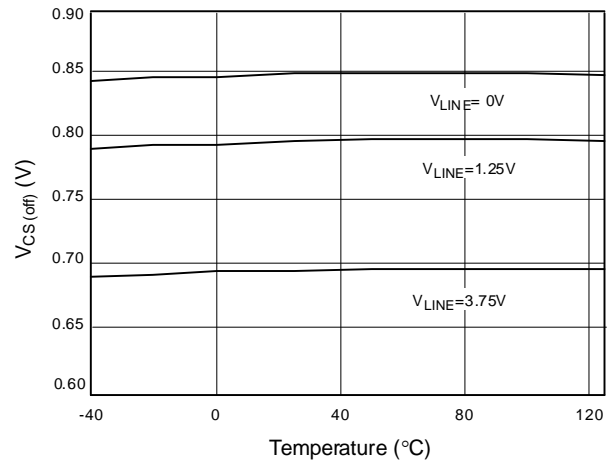

Fig. 8 Vcs (off) vs. Temperature

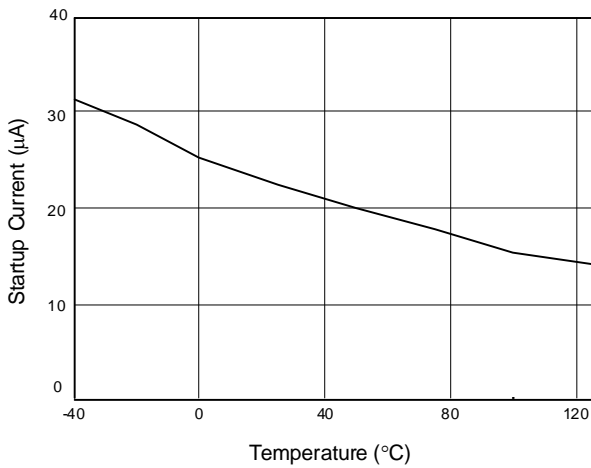

Fig. 9 Startup Current vs. Temperature

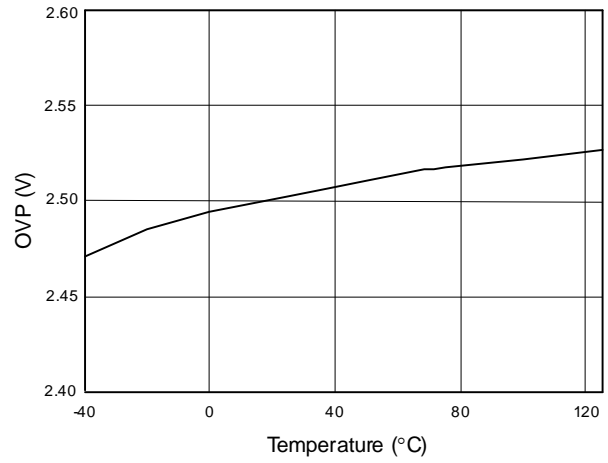

Fig. 10 OVP-Trip Level vs. Temperature

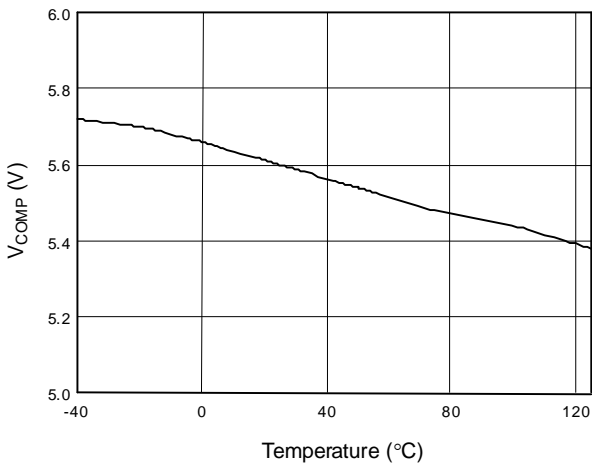

Fig. 11 V_{COMP} open-loop voltage vs. Temperature

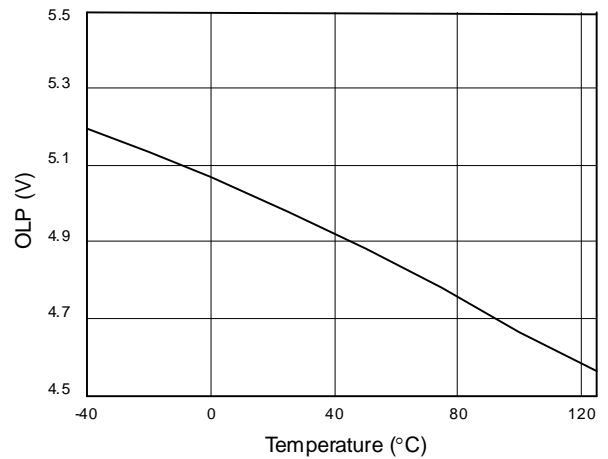

Fig. 12 OLP-Trip Level vs. Temperature

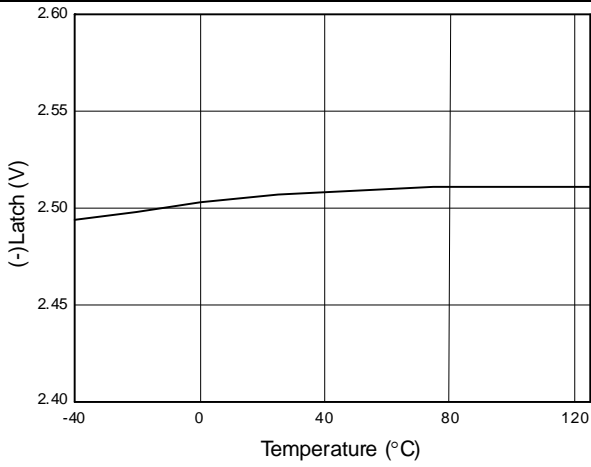

Fig. 13 (-)Latch Pin Off-Level vs. Temperature

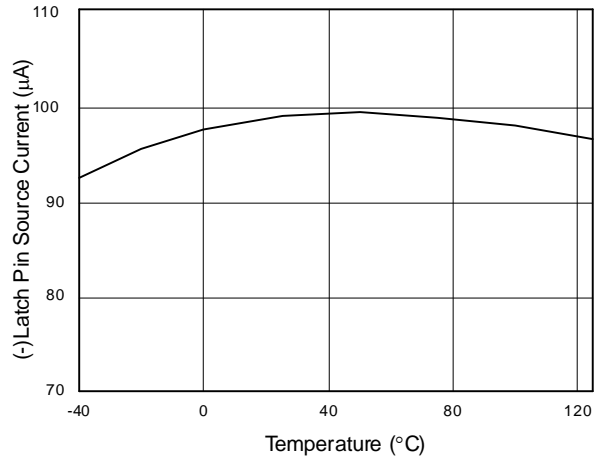

Fig. 14 (-)Latch Pin Source Current vs. Temperature

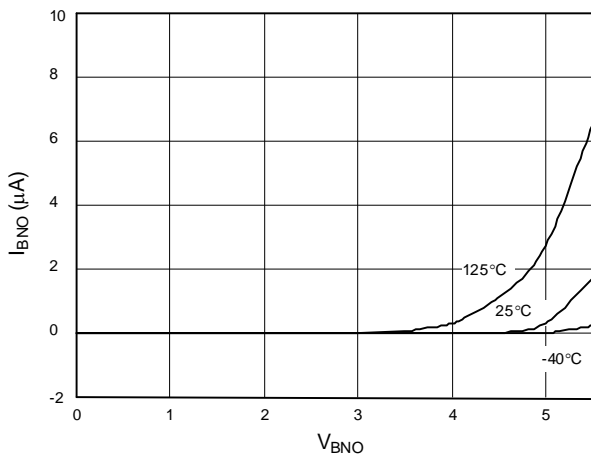

Fig. 15 V_{BNO} vs. I_{BNO}

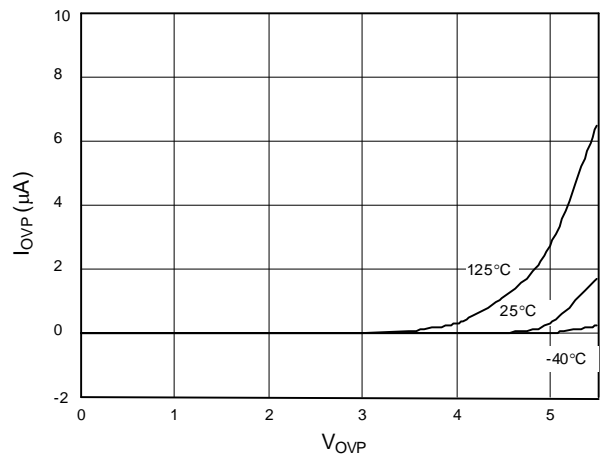

Fig. 16 V_{OVP} vs. I_{OVP}

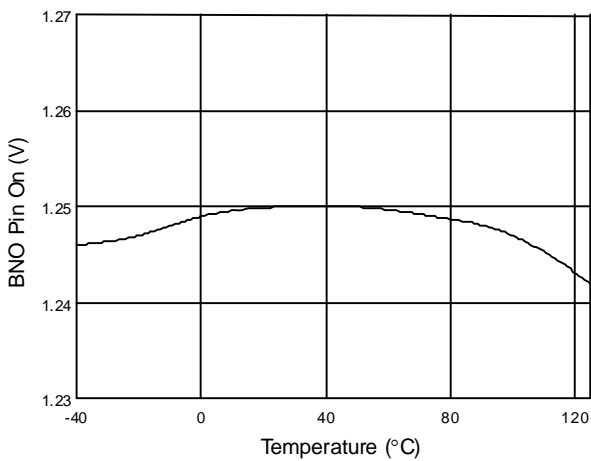

Fig. 17 BNO Pin On Level vs. Temperature

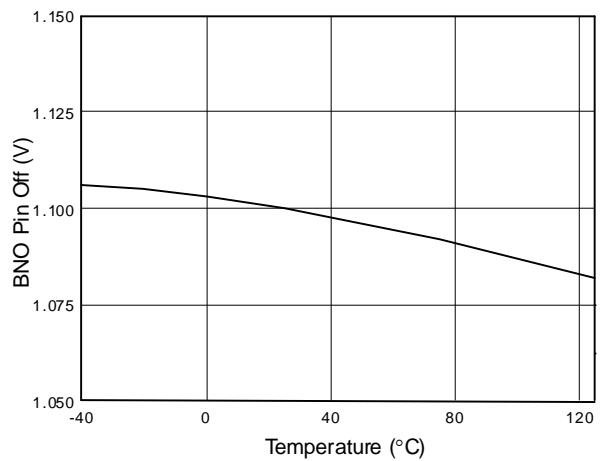

Fig. 18 BNO Pin Off Level vs. Temperature

Application Information

Operation Overview

As long as the green power requirement becomes a trend and the power saving is getting more and more important for the switching power supplies and switching adapters, traditional PWM controllers are not able to support such new requirements. Furthermore, the cost and size limitation forces the PWM controllers to powerfully integrate more functions for reducing the external part counts. The LD7523A is targeted on such applications and provides an easy and cost effective solution; its detailed features are described as below.

Under Voltage Lockout (UVLO)

An UVLO comparator is implemented in it to detect the voltage on the VCC pin, for assuring the supply voltage high enough to turn on the LD7523A PWM controller and to drive the power MOSFET. As shown in Fig. 19, a hysteresis is built in to prevent the shutdown due to the voltage dip during startup. The turn-on and turn-off threshold levels are set at 12.7V and 9.7V, respectively.

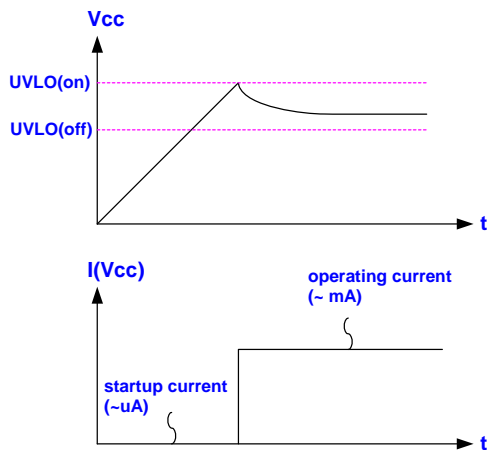

Fig. 19

Startup Current and Startup Circuit

The typical startup circuit for the LD7523A is shown in Fig. 20. During the startup transient, the Vcc is lower than the UVLO threshold and thus there is no gate pulse produced from the LD7523A to drive power MOSFET.

Therefore, the current through R1 will provide the startup current and to charge the capacitor C1. Whenever the Vcc voltage is high enough to turn on the LD7523A and further to deliver the gate drive signal, the supply current is provided from the auxiliary winding of the transformer. Lower startup current requirement on the PWM controller will help to increase the maximum value on R1 and then reduce the power consumption on R1. By using CMOS process and the special circuit design, the maximum startup current of LD7523A is only 35 μ A.

If a higher resistance value of the R1 is chosen, it usually takes more time to start up. Careful value selection of R1 and C1 will optimize the power consumption and startup time.

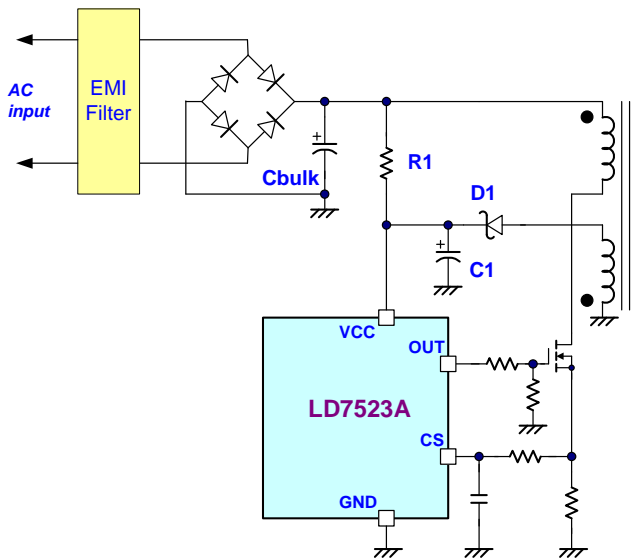

Fig. 20

Output Stage and Maximum Duty-Cycle

An output stage of a CMOS buffer, with typical 500mA driving capability, is incorporated to drive a power MOSFET directly. And the maximum duty-cycle of LD7523A is limited to 75% to avoid the transformer saturation.

Oscillator and Switching Frequency

The switching frequency of LD7523A is fixed at 65KHz internally to provide the optimized operations by considering the EMI performance, thermal treatment, component sizes and transformer design.

Voltage Feedback Loop

The voltage feedback signal is provided from the TL431 in the secondary side through the photo-coupler to the COMP pin of LD7523A. The input stage of LD7523A, like the UC384X, has 2 diodes voltage offset before feeding into the voltage divider with 1/3 ratio, that is,

$$V_{+(PWM_COMPARATOR)} = \frac{1}{3} \times (V_{COMP} - 2V_F)$$

A pulling-high resistor is embedded internally to eliminate the requirement of another resistor in the external circuit.

Dual-Oscillator Green-Mode Operation

There are many different topologies implemented in different chips for the green-mode or power saving requirements, such as “burst-mode control”, “skipping-cycle mode”, “variable off-time control “...etc. The basic operation theory of all these approaches intends to reduce the switching cycles under light-load or no-load condition either by skipping some switching pulses or reduce the switching frequency.

By using this dual-oscillator control, the green-mode frequency can be well controlled and further to avoid the generation of audible noise.

Internal Slope Compensation

A fundamental issue of current mode control is the stability problem when its duty-cycle is higher than 50%. To stabilize the control loop, slope compensation is needed in the traditional UC384X design by injecting the ramp signal from the RT/CT pin through a coupling capacitor. In the LD7523A, the internal slope compensation circuit has been internally implemented to simplify the external circuit design.

Current Sensing, Leading-edge Blanking

The typical current mode PWM controller feeds back both current signal and voltage signal to close the control loop and achieve regulation. The LD7523A detects the primary MOSFET current from the CS pin, which is not only for the peak current mode control but also for the pulse-by-pulse current limit. The maximum voltage threshold of the current sensing pin is set as 0.85V. Thus the MOSFET peak current can be calculated as:

$$I_{PEAK(MAX)} = \frac{(0.85 - V_{LINE_COMPENSATION})}{R_S}$$

A 350nS leading-edge blanking (LEB) time is included in the input of CS pin to prevent the false-trigger due to the current spike. However, the total pulse width of the turn-on spike is decided by the output power, circuit design and PCB layout. It is strongly recommended to adopt a smaller R-C filter (as shown in figure 21) to avoid the CS pin being damaged by the negative turn-on spike.

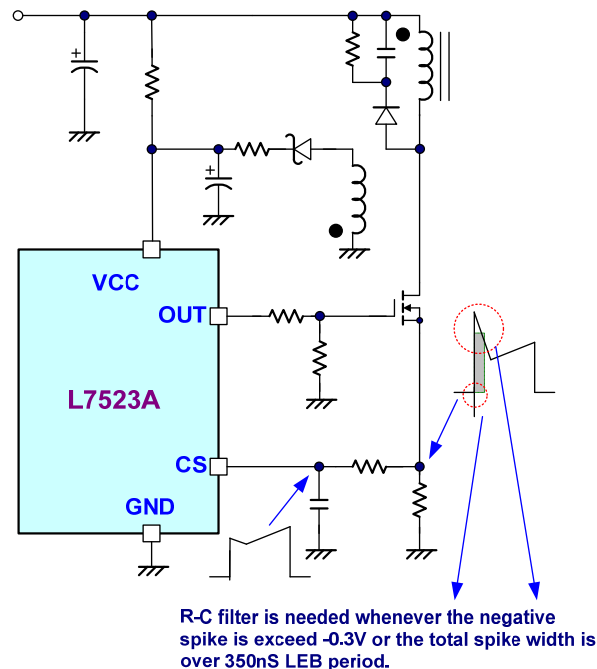

Fig. 21

Brownout Protection & Line Compensation

BNO pin plays 2 different roles in LD7523A. The major function is to set the brownout protection point, and at the same time, the second function provides the line compensation function like in LD7520.

Since the voltage on the BNO pin is proportional to the bulk capacitor voltage, representing the line voltage. A brownout comparator is implemented to detect the abnormal line condition and, upon detection it shuts down the controller to prevent damage. Figure 22 shows the operation. When V_{BNO} is lower than 1.25V, the gate output will be kept off even if the V_{cc} already achieves UVLO(on), therefore the V_{cc} will be hiccup between UVLO(on) and UVLO(off). Only if the line voltage is so high that V_{BNO} is higher than 1.25V, the gate output will start switching when the next UVLO(on) is tripped. A hysteresis is implemented to prevent the false trigger during turn-on and turn-off.

On the other hand, LD7523A detects the voltage on the BNO pin to feed the line compensation signal on the current sense circuit. Figure 23 shows the circuit. Thanks to this implementation, the OCP levels of high-line and low-line can be achieved at very close points.

The voltage gain from the BNO voltage to line compensation is 0.04 (V/V). The relationship between BNO pin voltage and the line compensation is illustrated in figure 24.

In order to protect BNO pin from being damaged during the dividing resistors floating, an internal zener diode is implemented in BNO pin. Fig. 15 shows the sinking capability of the zener diode. To protect BNO pin, the current flowing in BNO pin must be below $1.5\mu A$, as shown in Fig. 15.

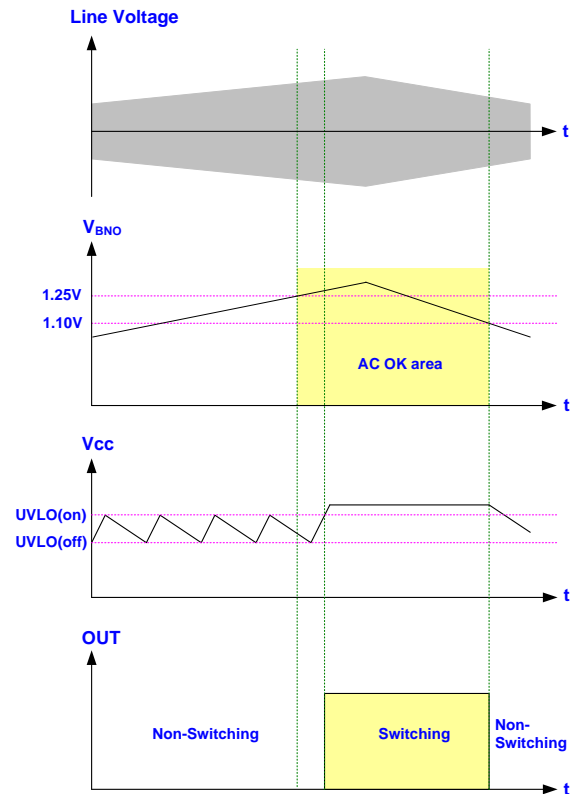

Fig. 22

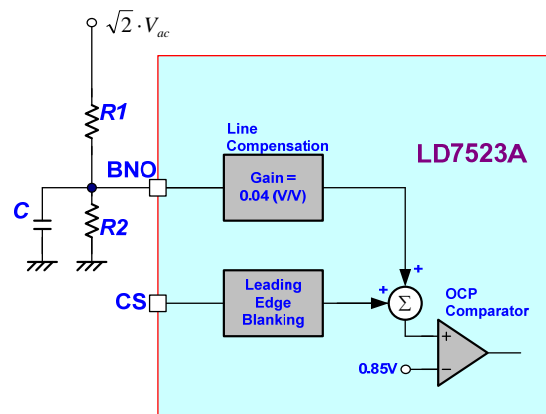

Fig. 23

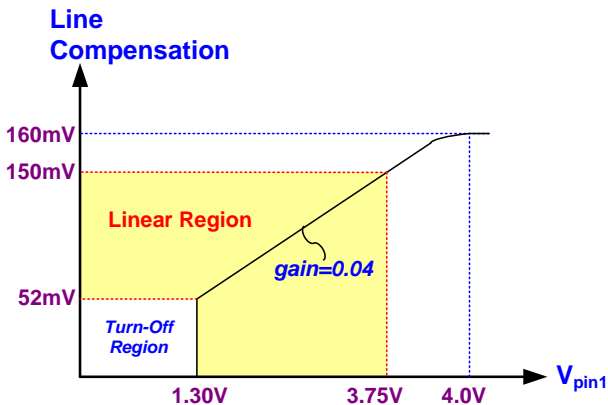

Fig. 24

Over Load Protection (OLP)

To protect the circuit from the damage during over load condition or short condition, a smart OLP function is implemented in the LD7523A. Figure 25 shows the waveforms of the OLP operation. Under such fault condition, the feedback system will force the voltage loop toward saturation and thus pull the voltage on COMP pin (VCOMP) to high. Whenever the VCOMP trips the OLP threshold, 5.0V, and keeps longer than 30mS, the protection is activated to turn off the gate output and stop the switching of power circuit. The 30mS delay time is to prevent the false trigger during the power-on and turn-off transient.

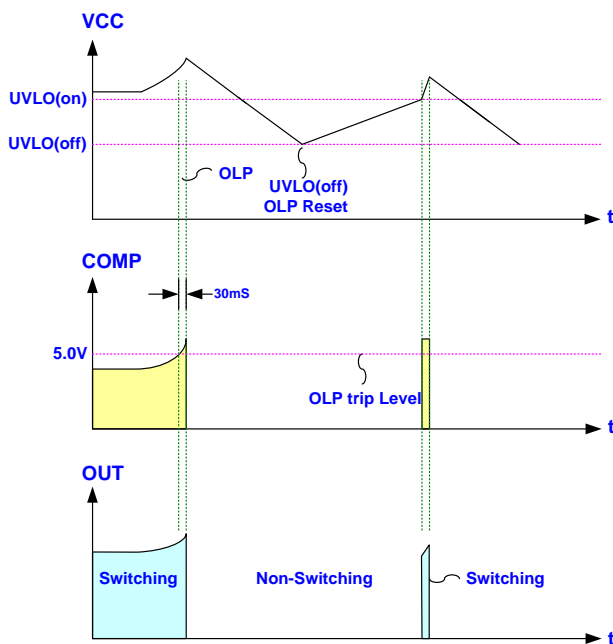

Fig. 25

By using such protection mechanism, the average input power can be reduced to a very low level so that the component temperature and stress can be controlled within a safe operating area.

Over Voltage Protection (OVP)

The Vgs ratings of the nowadays power MOSFETs most have the maximum of 30V. To prevent the component damage in a fault condition, the LD7523A is implemented with the protection through the OVP pin. Figure 26 and figure 27 show 2 different configurations to program the OVP setting point --- zener detection and voltage divider. Figure 26 shows zero bias current under normal operation so that it will not affect the startup timing. But the tolerance of OVP trip point will be higher due to the breakdown voltage variation of a discrete zener diode. On the other hand, the circuit of figure 27 will get the benefits on the cost and the OVP accuracy, but R1 and R2 must be of high resistance to avoid affecting the startup time due to the load effect.

As shown in figure 28, whenever the voltage on the OVP pin is higher than the threshold voltage 2.5V, the output gate drive circuit will be shut down simultaneously, stopping the switching of the power MOSFET. Whenever the voltage on the OVP pin gets back to lower than 2.5V, the output is automatically returned to the normal operation on the next UVLO(on) level.

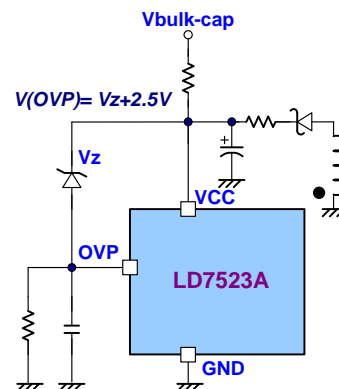

Fig. 26

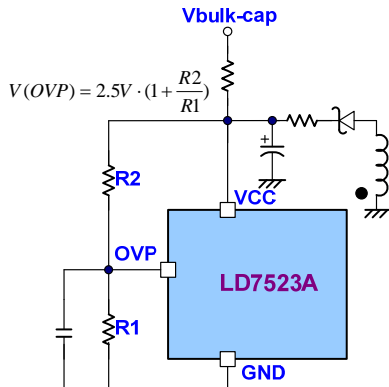

Fig. 27

and then latch off the power supply. For the LD7523A, the controller will be kept latched until the Vcc drops lower than 8V (power down reset) and the fault condition is removed. That means the gate output may still be kept off even the abnormal condition is released. The only way to successfully re-start the circuit needs to meet 2 conditions. One is to cool down the circuit and thus NTC resistance increases over 3.5V. Another condition is to remove the AC power cord and begin another AC power-on recycling. The detail operation is depicted as figure 29.

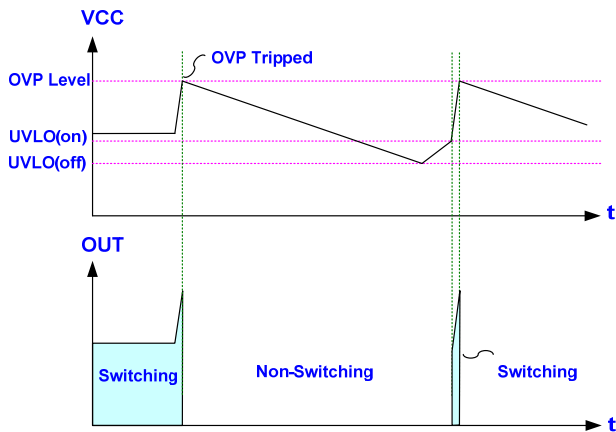

Fig. 28

(-)LATCH Pin and Over Temperature Protection (OTP) --- Latched Mode Protection

Under some abnormal conditions, the ambient temperature may be increased significantly, causing some damage on the components or, in a worsen scenario, endangering the users. Thus, the OTP is required. The OTP circuit is implemented by sensing a hot-spot of power circuit like a power MOSFET or an output rectifier. It can be easily achieved by connecting a NTC on the (-)LATCH pin of a LD7523A. When the device temperature or ambient temperature rises, the resistance of NTC decreases so that the voltage on the (-)LATCH pin will be $V_{(-)LATCH} = 100\mu A \times R_{NTC}$

When the $V_{(-)LATCH}$ is lower than the threshold voltage (typical 2.5V), LD7523A will shut down the gate output

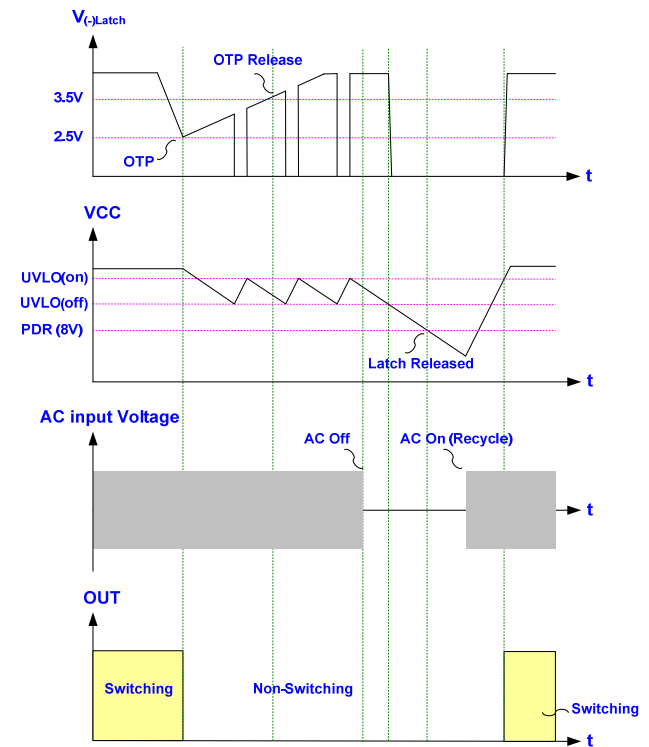

Fig. 29

Summary of Protections

There are several ways to control the on/off of LD7523A.

The details are listed as the table below.

	Turn Off	Operation
COMP	Comp Pin < 1.4V	Cycle by Cycle Mode Non-latch
OLP	Comp Pin > 5.0V	Hiccup Mode Non-latch Re-start after next UVLO(on)
OVP	OVP Pin > 2.5 V	
Brownout	BNO Pin < 1.25V with Hysteresis	
OTP	(-)LATCH Pin < 2.5V	Latch Mode

Table 1

Package Information

SOP-8

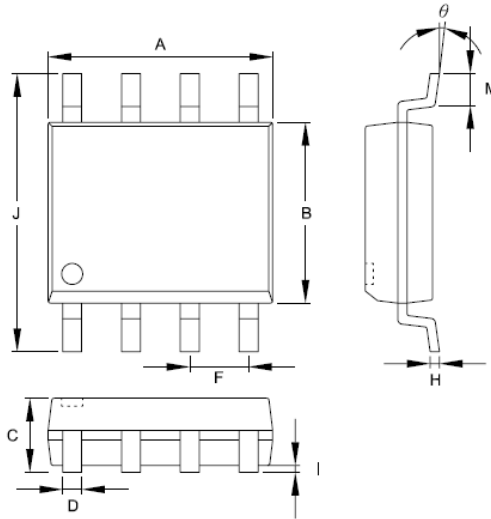

Symbols	Dimensions in Millimeters		Dimensions in Inch	
	MIN	MAX	MIN	MAX
A	4.801	5.004	0.189	0.197
B	3.810	3.988	0.150	0.157
C	1.346	1.753	0.053	0.069
D	0.330	0.508	0.013	0.020
F	1.194	1.346	0.047	0.053
H	0.178	0.229	0.007	0.009
I	0.102	0.254	0.004	0.010
J	5.791	6.198	0.228	0.244
M	0.406	1.270	0.016	0.050
θ	0°	8°	0°	8°

Package Information

DIP-8

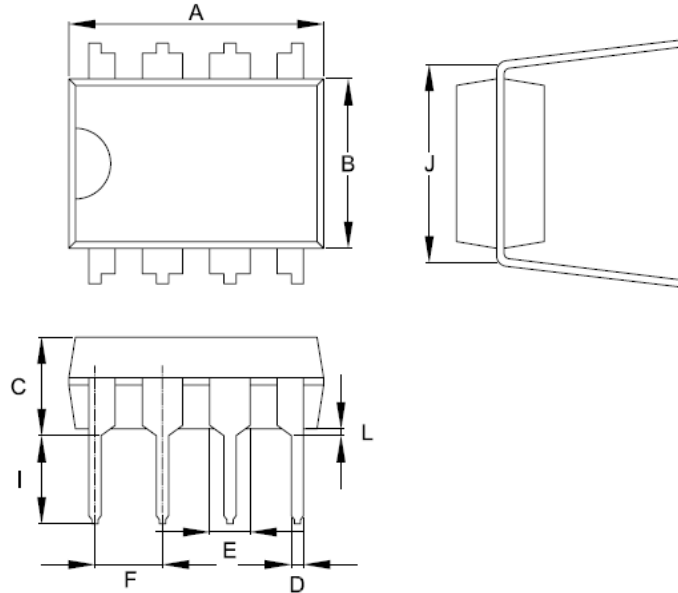

Symbol	Dimension in Millimeters		Dimensions in Inches	
	Min	Max	Min	Max
A	9.017	10.160	0.355	0.400
B	6.096	7.112	0.240	0.280
C	-----	5.334	-----	0.210
D	0.356	0.584	0.014	0.023
E	1.143	1.778	0.045	0.070
F	2.337	2.743	0.092	0.108
I	2.921	3.556	0.115	0.140
J	7.366	8.255	0.29	0.325
L	0.381	-----	0.015	-----

Important Notice

Leadtrend Technology Corp. reserves the right to make changes or corrections to its products at any time without notice. Customers should verify the datasheets are current and complete before placing order.

Revision History

Rev.	Date	Change Notice
00	10/27/2008	Original specification.
01	12/11/2008	Additional remark on BNO pin