

TOSHIBA BIPOLAR LINEAR INTEGRATED CIRCUIT SILICON MONOLITHIC

TA8127N, TA8127F

3V AM / FM 1CHIP TUNER IC

TA8127N and TA8127F are the AM/FM 1Chip Tuner ICs, which are designed for Portable Radios and 3V Headphone Radios.

FEATURES

- Built-in
 - FM F/E, AM/FM IF and FM MPX
- AM Detector Coil and IF Coupling Condenser are not needed.
- Compact Package
 - TA8127N : Shrink DIP 24 pin (1.78mm pitch)
 - TA8127F : Mini Flat Package 24 pin
- Operating Supply Voltage Range
 - $V_{CC} = 1.8 \sim 7.0V$ ($T_a = 25^\circ C$)

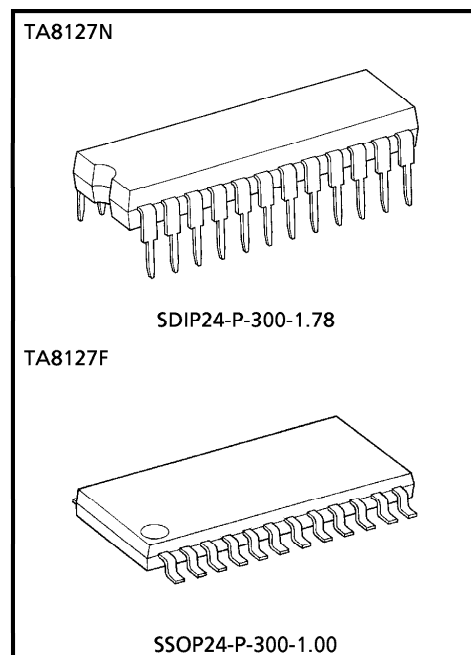

Weight

SDIP24-P-300-1.78	: 1.2g (Typ.)
SSOP24-P-300-1.00	: 0.31g (Typ.)

961001EBA2

- TOSHIBA is continually working to improve the quality and the reliability of its products. Nevertheless, semiconductor devices in general can malfunction or fail due to their inherent electrical sensitivity and vulnerability to physical stress. It is the responsibility of the buyer, when utilizing TOSHIBA products, to observe standards of safety, and to avoid situations in which a malfunction or failure of a TOSHIBA product could cause loss of human life, bodily injury or damage to property. In developing your designs, please ensure that TOSHIBA products are used within specified operating ranges as set forth in the most recent products specifications. Also, please keep in mind the precautions and conditions set forth in the TOSHIBA Semiconductor Reliability Handbook.
- The products described in this document are subject to foreign exchange and foreign trade control laws.
- The information contained herein is presented only as a guide for the applications of our products. No responsibility is assumed by TOSHIBA CORPORATION for any infringements of intellectual property or other rights of the third parties which may result from its use. No license is granted by implication or otherwise under any intellectual property or other rights of TOSHIBA CORPORATION or others.
- The information contained herein is subject to change without notice.

BLOCK DIAGRAM

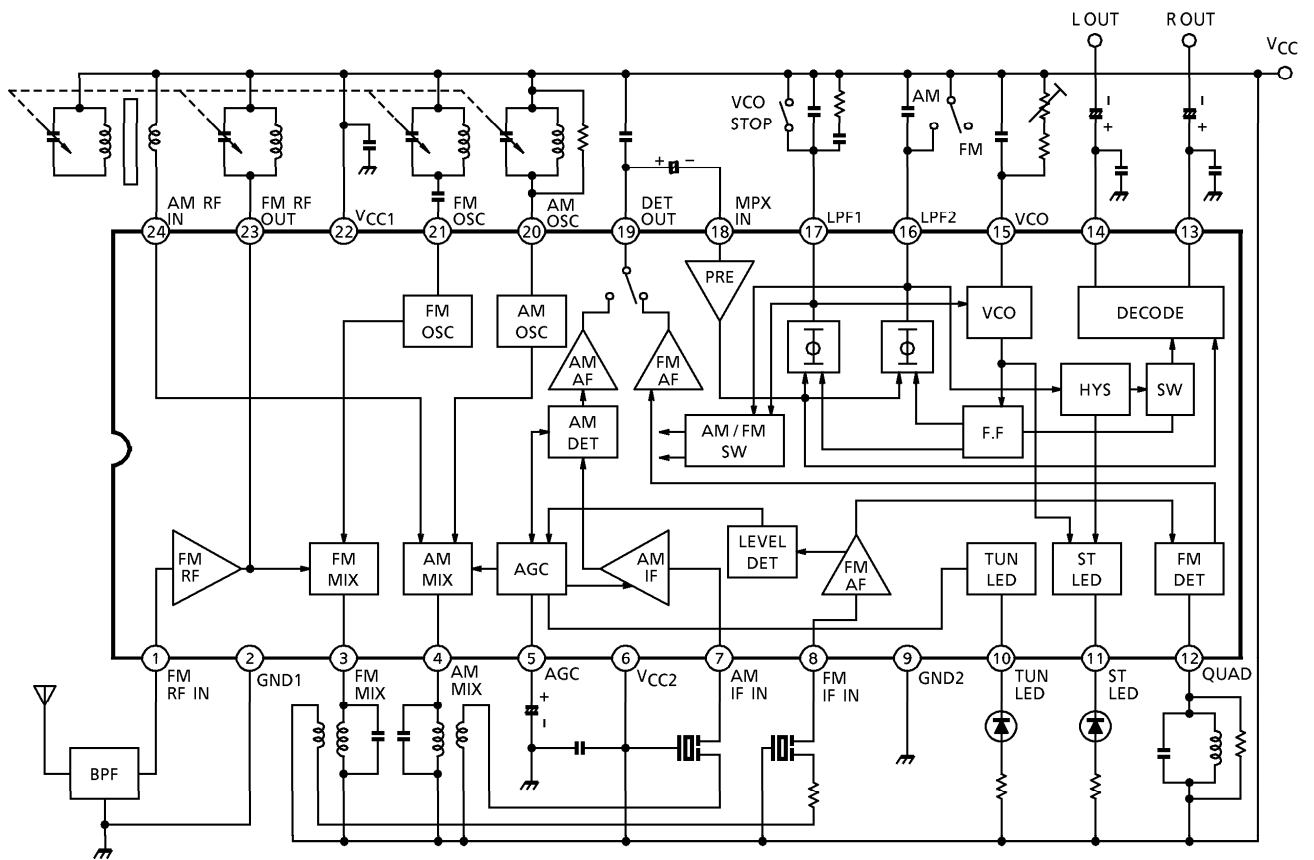

EXPLANATION OF TERMINALS

PIN NO.	ITEM	INTERNAL CIRCUIT	DC VOLTAGE (V) (AT NO SIGNAL)	
			AM	FM
1	FM-RF IN		0	0.7
2	GND1 (GND for RF Stage)	—	0	0
3	FM MIX		3.0	3.0
4	AM MIX		3.0	3.0
5	AGC (AM AGC)		0	0
6	VCC2 (VCC for IF / MPX Stage)	—	3.0	3.0
7	AM IF IN		3.0	3.0
8	FM IF IN		3.0	3.0

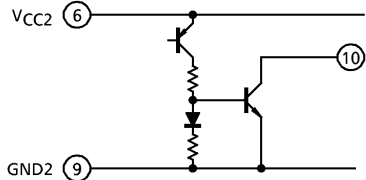
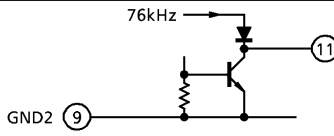
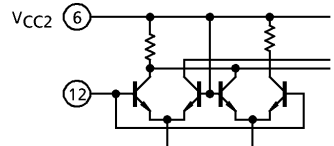
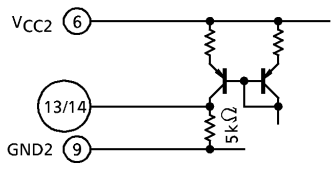
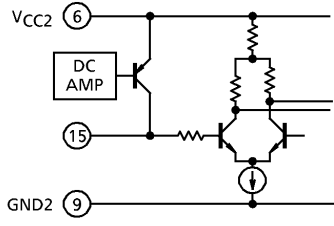
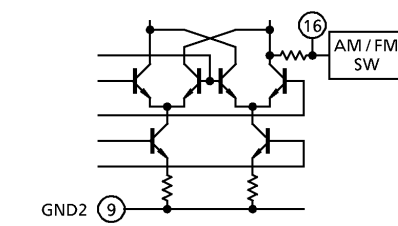
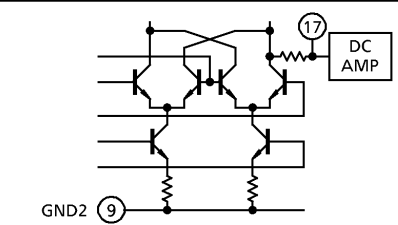
PIN NO.	ITEM	INTERNAL CIRCUIT	DC VOLTAGE (V) (AT NO SIGNAL)	
			AM	FM
9	GND2 (GND for IF/MPX Stage)	—	0	0
10	TUN LED (Tuning LED)		—	—
11	ST LED (Stereo LED)		—	—
12	QUAD (FM QUAD. Detector)		3.0	3.0
13	R-OUT (R-ch Output)		1.0	1.0
14	L-OUT (L-ch Output)			
15	VCO		2.5	2.5 (VCO STOP MODE)
16	LPF2 <ul style="list-style-type: none"> ● LPF Terminal for Synchronous Detector ● Bias Terminal for AM / FM SW Circuit $V_{16} = V_{CC} \rightarrow \text{AM (VCO Stop)}$ $V_{16} = \text{Open} \rightarrow \text{FM}$		3.0	2.2 (VCO STOP MODE) 2.7
17	LPF1 <ul style="list-style-type: none"> ● LPF Terminal for Phase Detector ● VCO Stop Terminal $V_7 = V_{CC} \rightarrow \text{VCO Stop}$		2.7	2.2

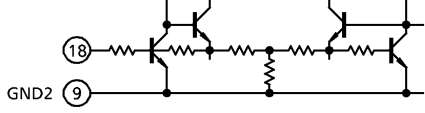
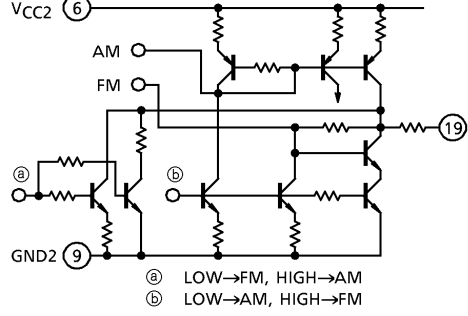
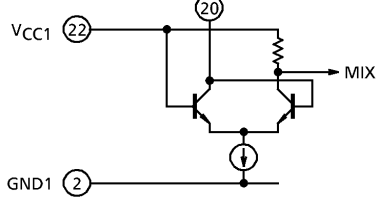
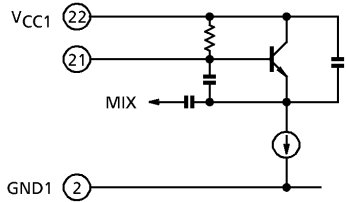
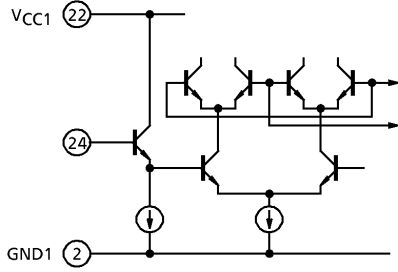
PIN NO.	ITEM	INTERNAL CIRCUIT	DC VOLTAGE (V) (AT NO SIGNAL)	
			AM	FM
18	MPX IN		0.7	0.7
19	DET OUT		1.5	1.2
20	AM OSC		3.0	3.0
21	FM OSC		3.0	3.0
22	VCC1 (VCC for RF Stage)	—	3.0	3.0
23	FM RF OUT	cf. pin①	3.0	3.0
24	AM RF IN		3.0	3.0

MAXIMUM RATINGS (Ta = 25°C)

CHARACTERISTIC		SYMBOL	RATING	UNIT
Supply Voltage		V _{CC}	8	V
LED Current		I _{LED}	10	mA
LED Voltage		V _{LED}	8	V
Power Dissipation	TA8127N	P _D (Note)	1200	mW
	TA8127F		400	
Operating Temperature		T _{opr}	- 25~75	°C
Storage Temperature		T _{stg}	- 55~150	°C

Note : Derated above 25°C in the proportion of 9.6mW/°C for TA8127N and of 3.2mW/°C for TA8127F.

ELECTRICAL CHARACTERISTICS

Unless otherwise specified,

Ta = 25°C, VCC = 3V, F/E : f = 83MHz, fm = 1kHz
 FM IF : f = 10.7MHz, Δf = ± 22.5kHz, fm = 1kHz
 AM : f = 1MHz, MOD = 30%, fm = 1kHz
 MPX : fm = 1kHz

CHARACTERISTIC		SYMBOL	TEST CIR-CUIT	TEST CONDITION	MIN.	TYP.	MAX.	UNIT
Supply Current		I _{CC} (FM)	1	V _{in} = 0, FM Mode	—	13.2	20.0	mA
		I _{CC} (AM)	1	V _{in} = 0, AM Mode	—	8.4	13.5	
F/E	Input Limiting Voltage	V _{in} (lim.)	1	- 3dB Limiting	—	10.0	—	dB _{μV} EMF
	Local OSC Voltage	V _{OSC}	2	f _{OSC} = 72.3MHz	—	105	—	mV _{rms}
FM IF	Input Limiting Voltage	V _{in} (lim.) IF	1	- 3dB Limiting	40	46	53	dB _{μV} EMF
	Recovered Output Voltage	V _{OD}	1	V _{in} = 80dB _{μV} EMF	55	80	110	mV _{rms}
	Signal to Noise Ratio	S/N	1	V _{in} = 80dB _{μV} EMF	—	70	—	dB
	Total Harmonic Distortion	THD	1	V _{in} = 80dB _{μV} EMF	—	0.4	—	%
	AM Rejection Ratio	AMR	1	V _{in} = 80dB _{μV} EMF	—	32	—	dB
	Lamp ON sensitivity	V _L	1	I _L = 1mA	45	51	56	dB _{μV} EMF
AM	Gain	G _V	1	V _{in} = 26dB _{μV} EMF	40	70	110	mV _{rms}
	Recovered Output Voltage	V _{OD}	1	V _{in} = 60dB _{μV} EMF	55	80	110	
	Signal to Noise Ratio	S/N	1	V _{in} = 60dB _{μV} EMF	—	42	—	dB
	Total Harmonic Distortion	THD	1	V _{in} = 60dB _{μV} EMF	—	1.0	—	%
	Lamp ON Sensitivity	V _L	1	I _L = 1mA	20	25	30	dB _{μV} EMF
Pin ^① Output Resistance		R ₁₉	1	FM Mode	—	0.75	—	kΩ
				AM Mode	—	12.5	—	

CHARACTERISTIC		SYMBOL	TEST CIRCUIT	TEST CONDITION	MIN.	TYP.	MAX.	UNIT		
MPX	Input Resistance	R _{IN}	—	—	—	24	—	kΩ		
	Output Resistance	R _{OUT}	—	—	—	5	—			
	Max. Composite Signal Input Voltage		V _{in} (max.) STEREO	1	L + R = 90%, P = 10% f _m = 1kHz, THD = 3%	—	350	—	mV _{rms}	
	Separation		Sep	1	L + R =	f _m = 100Hz	—	42	—	dB
					135mV _{rms}	f _m = 1kHz	35	42	—	
					P = 15mV _{rms}	f _m = 10kHz	—	42	—	
	Total Harmonic Distortion	Monaural	THD (MONAURAL)	1	V _{in} = 150mV _{rms}		—	0.2	—	%
		Stereo	THD (STEREO)		L + R = 135mV _{rms} , P = 15mV _{rms}		—	0.2	—	
	Voltage Gain		G _V (MPX)	1	V _{in} = 150mV _{rms}		-5	-3	-1	dB
	Channel Balance		C.B.	1	V _{in} = 150mV _{rms}		-2	0	2	
	Stereo Lamp Sensitivity	ON	V _L (ON)	1	Pilot Input		—	8	16	mV _{rms}
		OFF	V _L (OFF)		Pilot Input		2	6	—	
Stereo Lamp Hysteresis		V _H	1	To LED turn off from LED turn on		—	2	—	mV _{rms}	
Capture Range		C.R.	1	P = 15mV _{rms}		—	±3	—	%	
Signal to Noise Ratio		S/N	1	V _{in} = 150mV _{rms}		—	70	—	dB	

TEST CIRCUIT 1

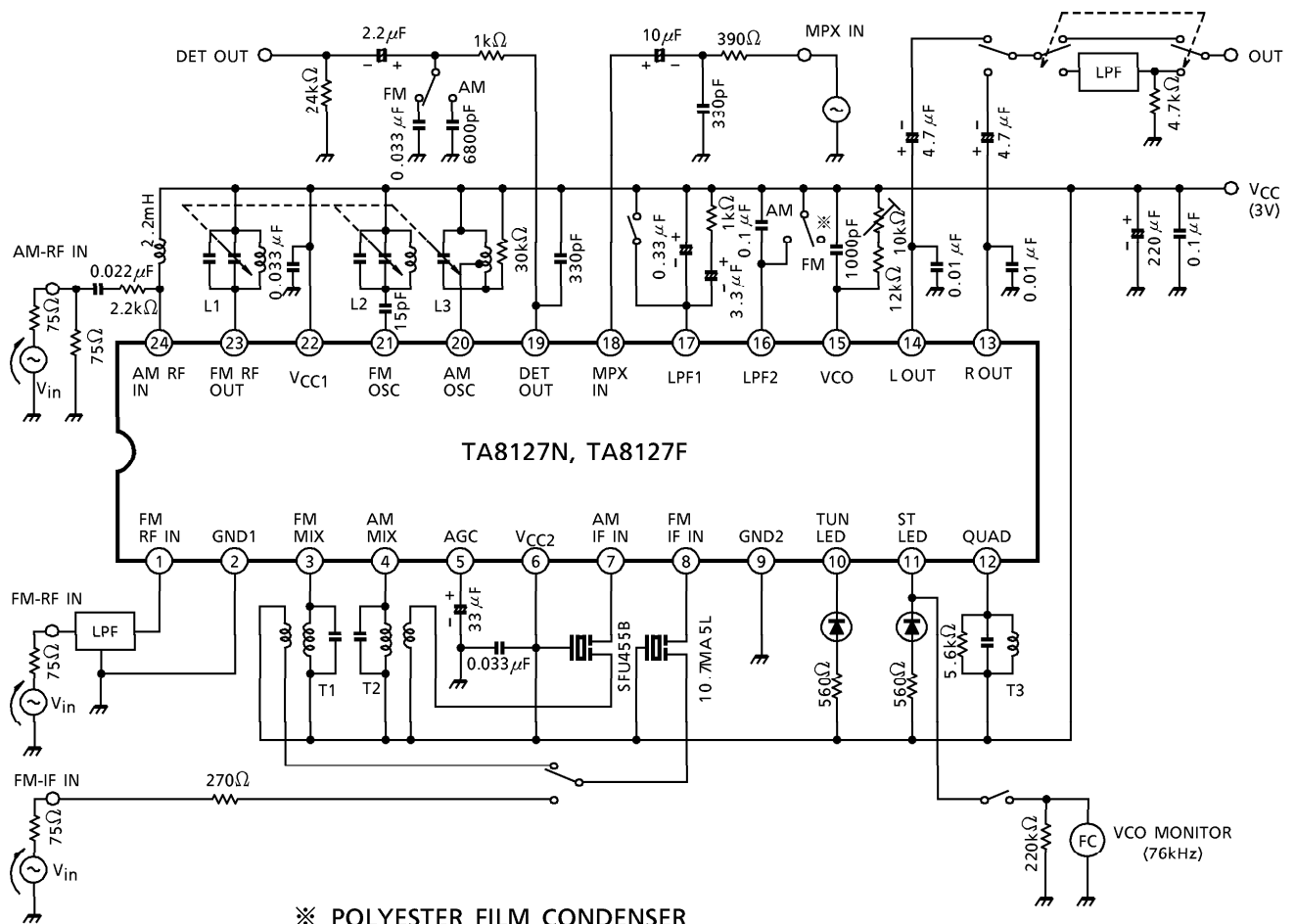

※ POLYESTER FILM CONDENSER

Using other types of condensers, there are some cases that the MPX does not do normal stereo action at high temperature or low temperature.

TEST CIRCUIT 2

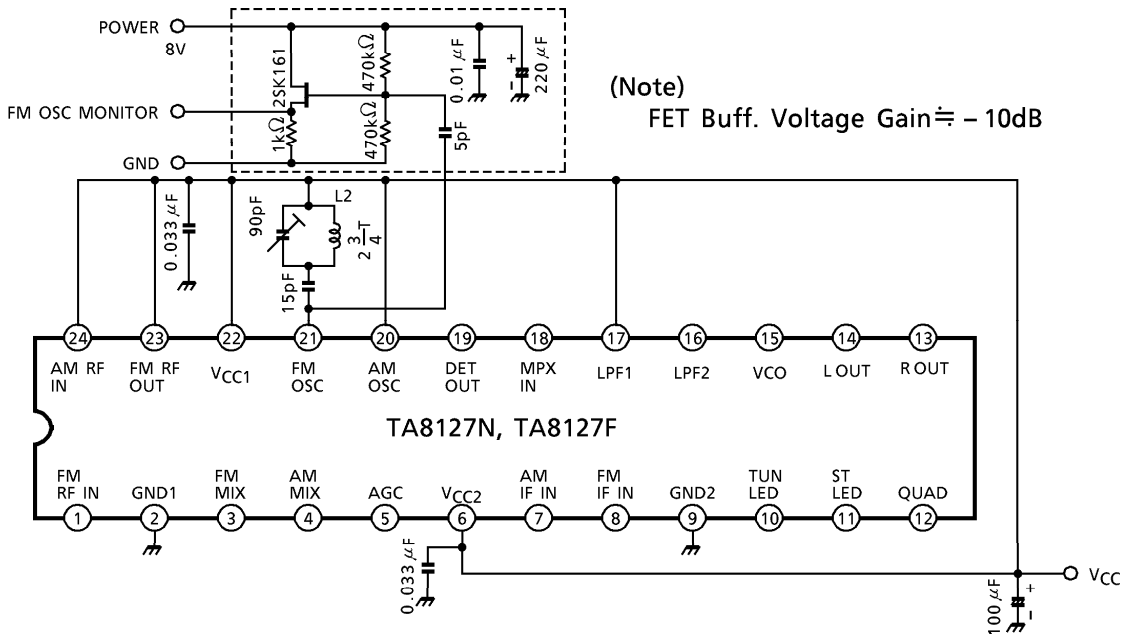

COIL DATA

COIL No.	TEST FREQ. (Hz)	L (μ H)	C ₀ (pF)	Q ₀	TURNS					WIRE (mm ϕ)	REFERENCE
					1-2	2-3	1-3	1-4	4-6		
L ₁ FM RF	100M	—	—	100	—	—	—	2 $\frac{1}{2}$	—	0.5UEW	Ⓢ 53T-037-202
L ₂ FM OSC	100M	—	—	100	—	—	2 $\frac{3}{4}$	—	—	0.5UEW	Ⓢ 0258-244
L ₃ AM OSC	796k	288	—	115	13	73	—	—	—	0.08UEW	Ⓢ 4147-1356-038
T ₁ FM MIX	10.7M	—	75	100	—	—	13	—	2	0.1UEW	Ⓢ 2153-414-041
T ₂ AM MIX	455k	—	180	120	—	—	180	—	15	0.08UEW	Ⓢ 2150-2162-165
T ₃ FM DET	10.7M	—	47	165	—	—	16	—	—	0.09UEW	Ⓢ 2153-4095-122

Ⓢ : SUMIDA ELECTRIC CO., LTD

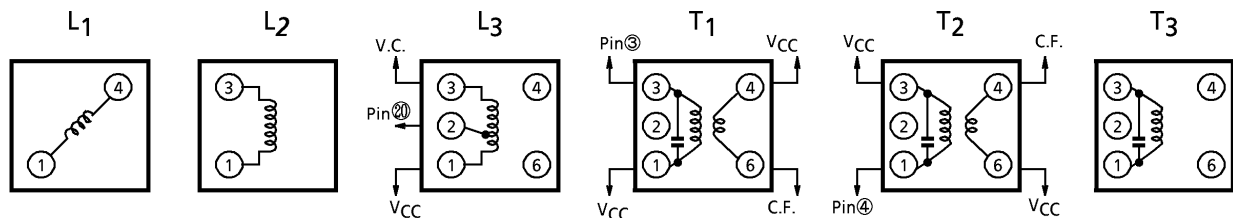

HINT ON USE OF TA8127N and TA8127F

External Parts of MPX VCO

(1) Temperature characteristic of MPX VCO free-run frequency. The temperature characteristic of MPX VCO is shown in the diagram as below. Select one with a better temperature characteristic (C, R and VR.) in use. We recommend,

- C : POLYESTER FILM
- R, VR. : CARBON FILM

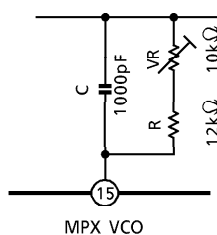
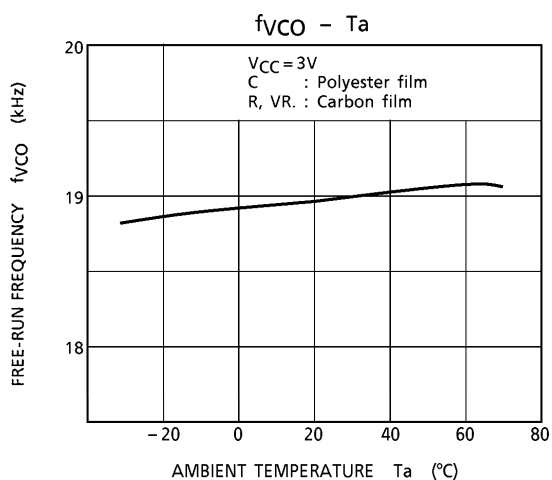

(2) Value of the external parts

We recommend to set up these value as below.

- R = 12kΩ
- VR = 10kΩ
- C = 1000pF

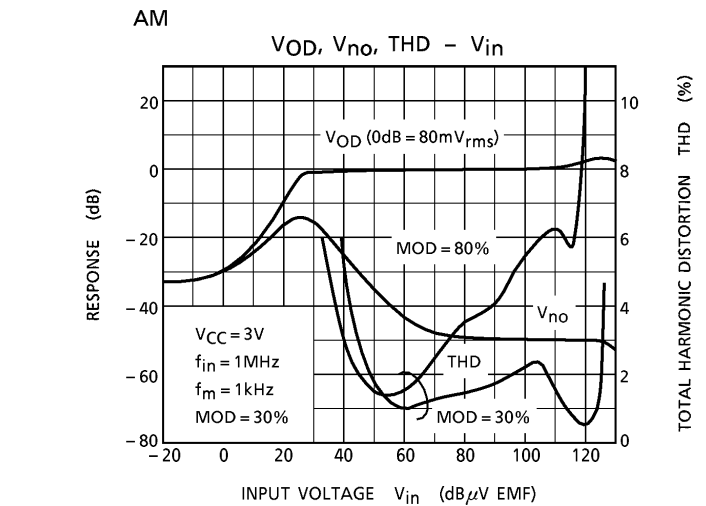
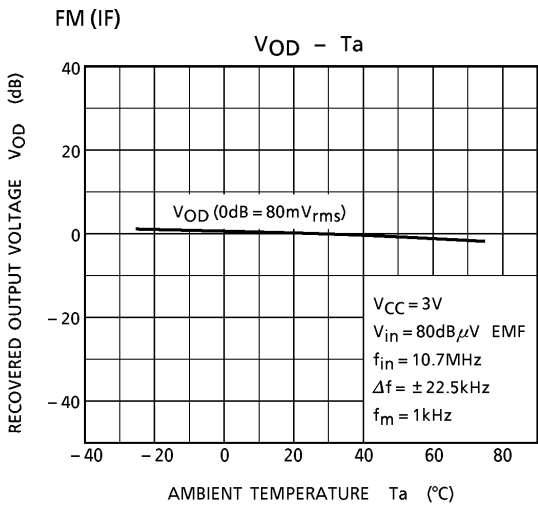
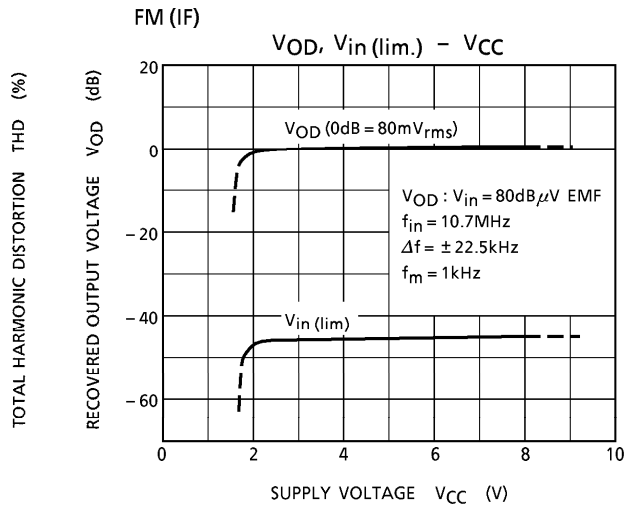
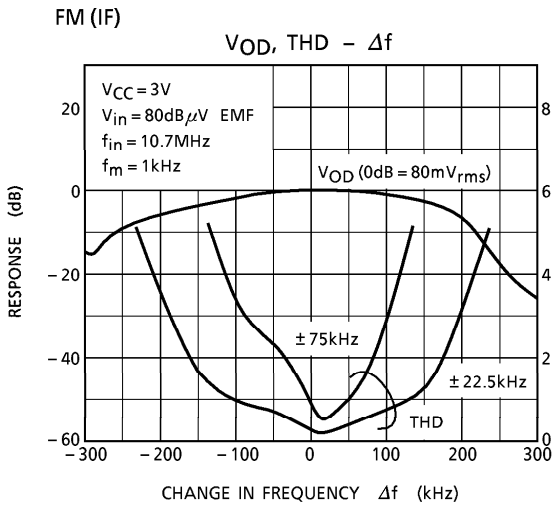
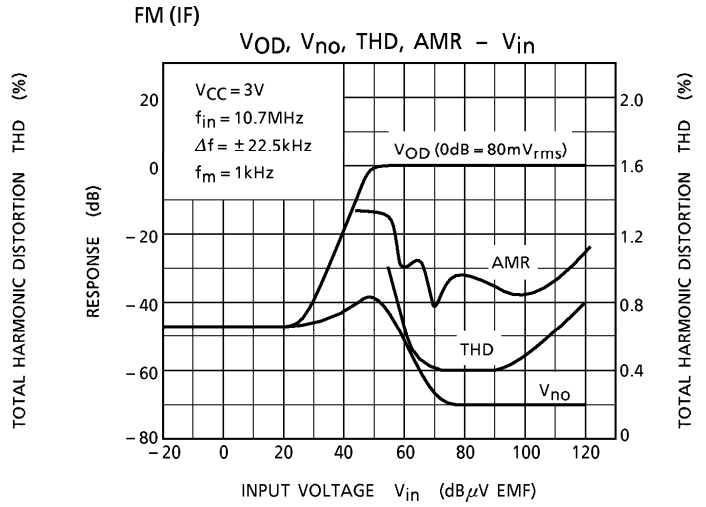
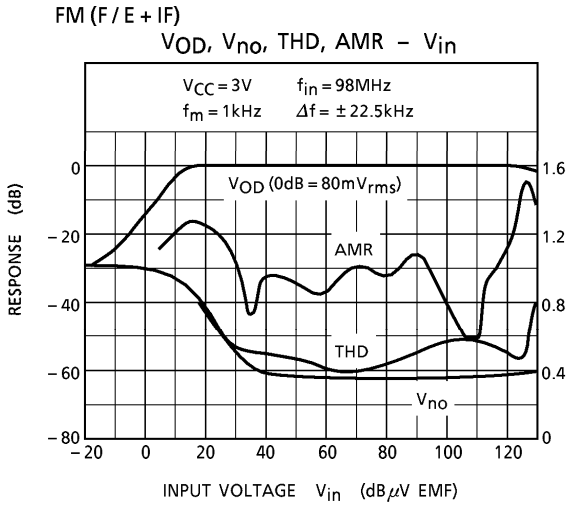

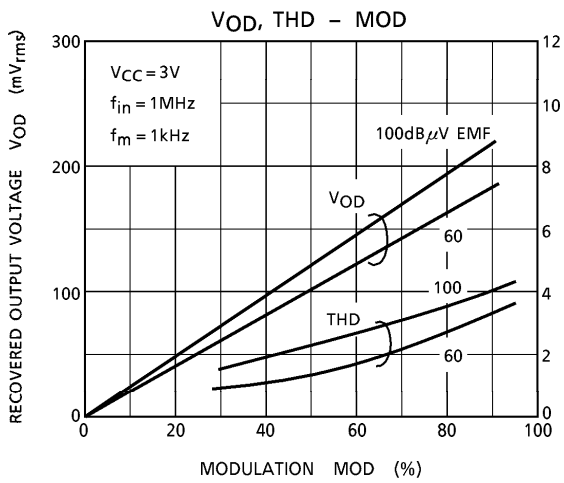

TOTAL HARMONIC DISTORTION THD (%)

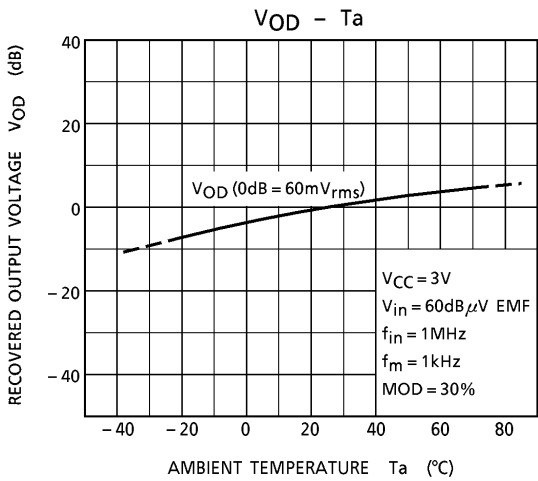
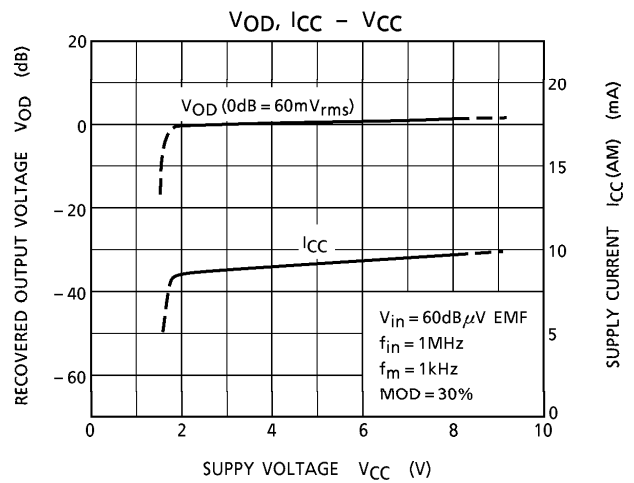

MPX

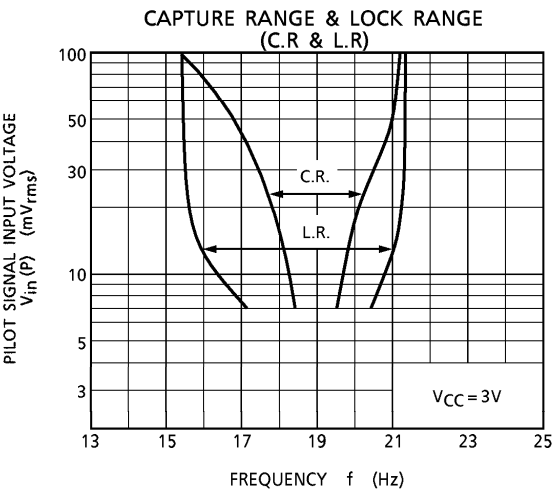
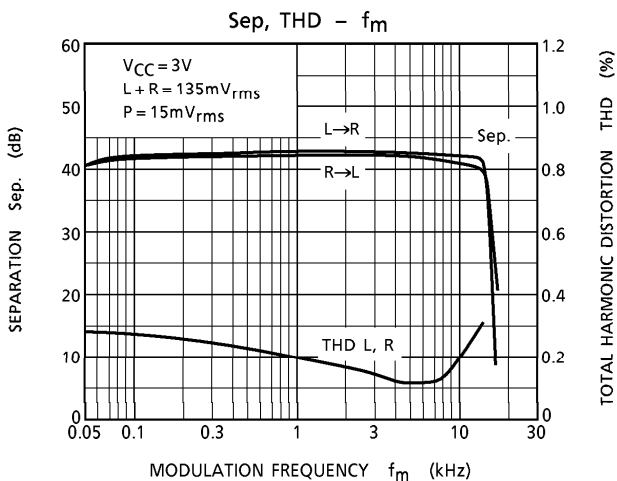
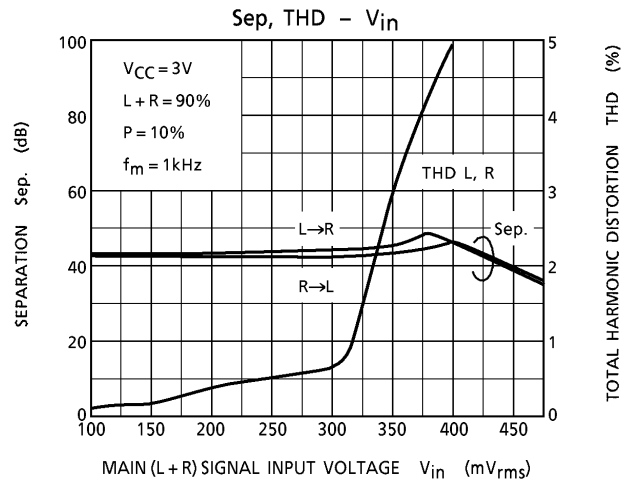

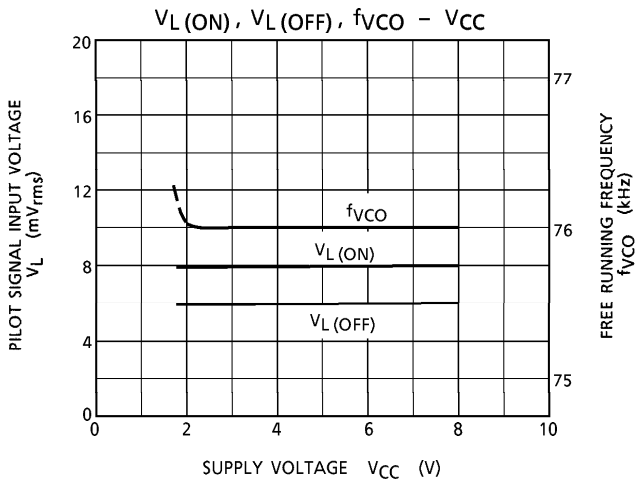
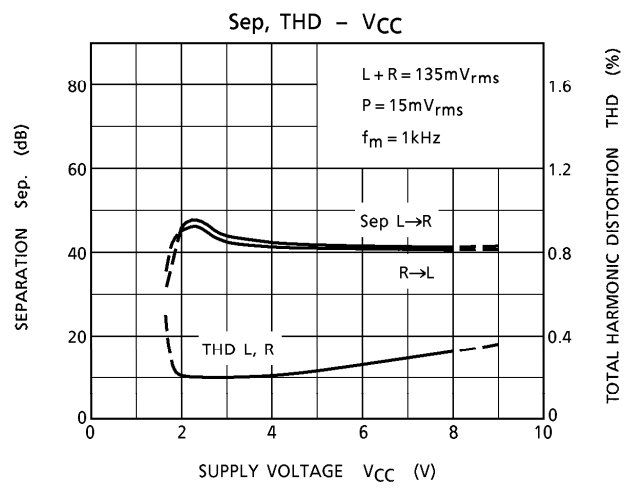
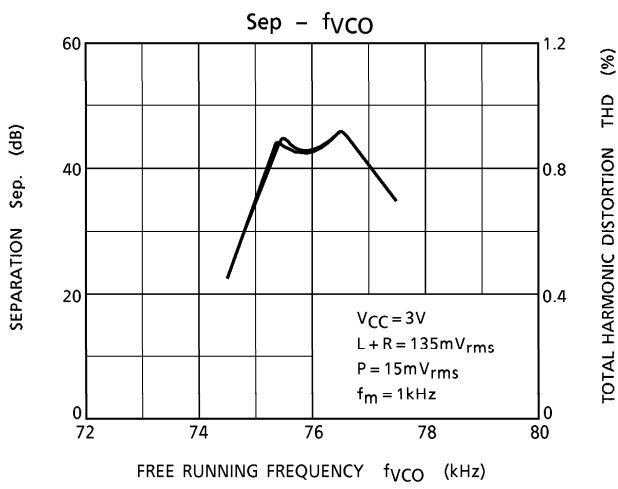

OUTLINE DRAWING
SDIP24-P-300-1.78

Unit : mm

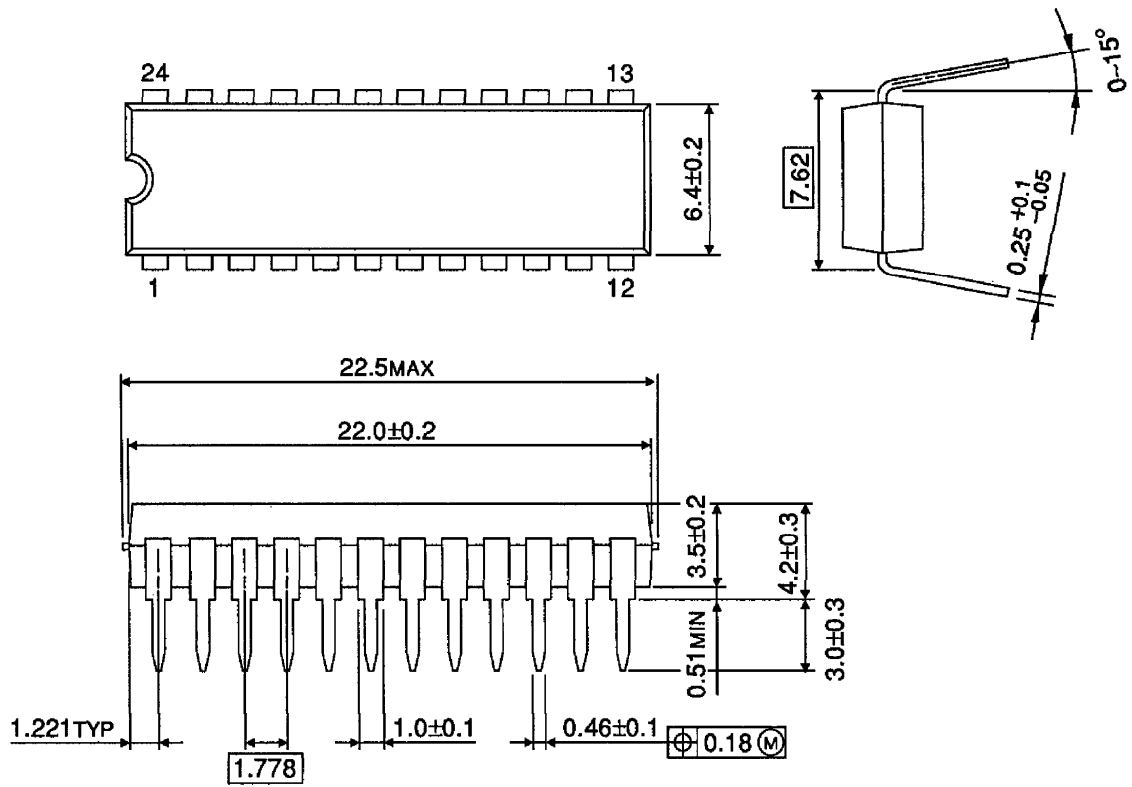

Weight : 1.2g (Typ.)

OUTLINE DRAWING
SSOP24-P-300-1.00

Unit : mm

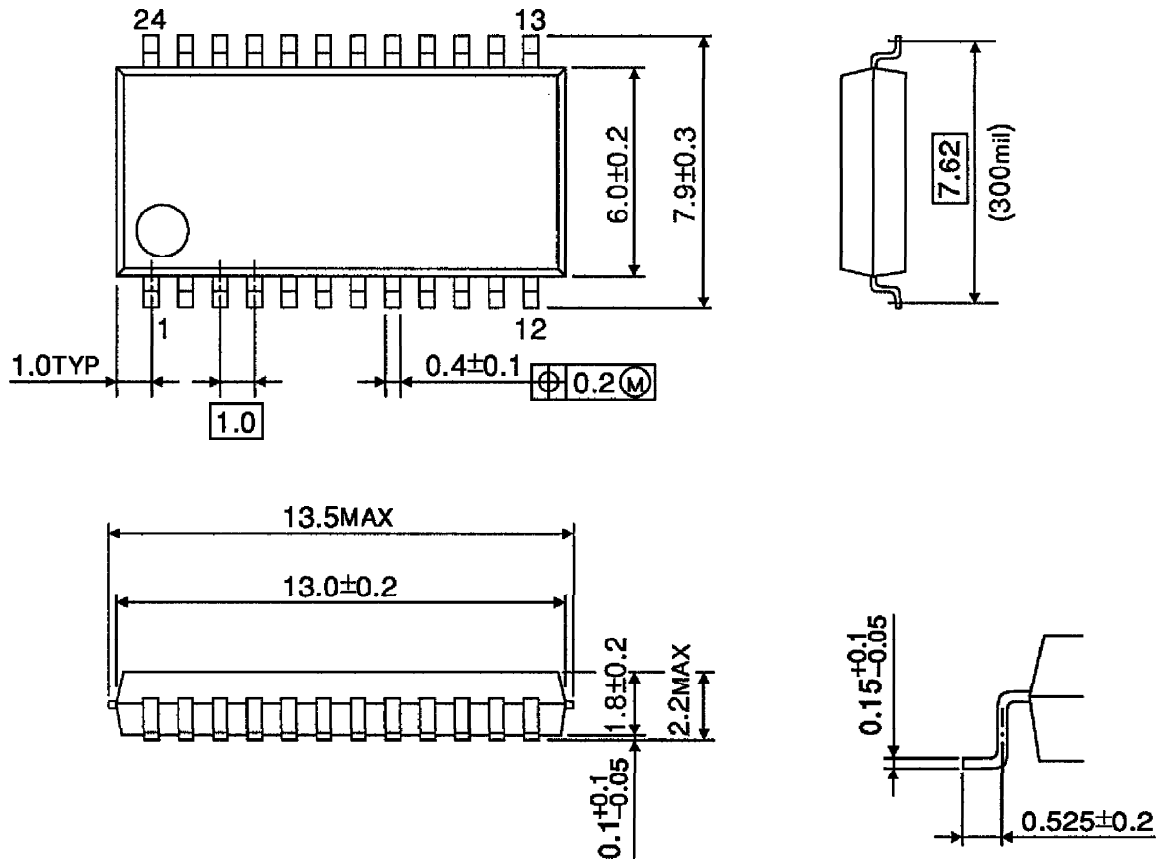

Weight : 0.31g (Typ.)